



For Members of  
**RADIO MANUFACTURERS SERVICE**  
A PHILCO SERVICE PLAN

**SERVICE BULLETIN**  
**No. 242**

**Model 37-600**

**Specifications**

- TYPE CIRCUIT:** Superheterodyne with pentode output.
- POWER SUPPLY:** 115 V., 60 cycle A.C.
- TUBES USED:** 1 type 6A8G, Det. Osc., 1 type 6J7G, 2nd Det., 1 type 6K6G, Output, 1 type 5Y4G Rectifier.
- FREQUENCY RANGE:** 530-1800 K.C.
- INTERMEDIATE FREQUENCY:** 470 K.C.
- CURRENT CONSUMPTION:** 45 watts.
- SPEAKER:** B-6.
- POWER OUTPUT:** 1/2 watt.

**Adjusting Compensating Condensers**

To accurately adjust the compensating condensers in the Model 37-600 receiver, it is necessary to use a signal generator of high stability on all frequencies, such as the PHILCO Model 088 Signal Generator. This instrument has a continuous frequency range from 110 to 20,000 K.C., and is designed to meet every requirement of the serviceman.

An output meter is also needed.—PHILCO MODEL 025 Circuit Tester includes a very sensitive output meter.

Convenient tools to use in adjusting the compensators are the Philco No. 3164 Fibre Wrench and No. 27-7059 Fibre Handled Screw-driver.

The locations of the various compensating condensers are shown in Fig. 1. Connect the output meter to the plate and cathode contacts of the 6K6G power tube, and adjust it to use the 0-30 volt range.

When adjusting each circuit, care should be taken to have the signal generator attenuator set for approximately 1/4 scale reading on output meter.

**Intermediate Frequency Circuit**

1. Connect the 088 signal generator output lead through a .1 mfd. condenser to the grid of the 6A8G tube and the ground lead to the chassis.
2. Turn the sensitivity compensator 23 to maximum capacity position (clockwise), and then release it; 1 1/2 turns (counter-clockwise).
3. Turn gang condenser to approximately 600 K.C. Set the signal generator at 470 K.C.
4. Adjust the compensator 18 and 20 for maximum reading on the output meter. Then turn the sensitivity compensator 23 clockwise until a hiss, (oscillation) is heard. Now turn the compensator 23 counter-clockwise until hiss ceases, then continue for 1/4 turn more.

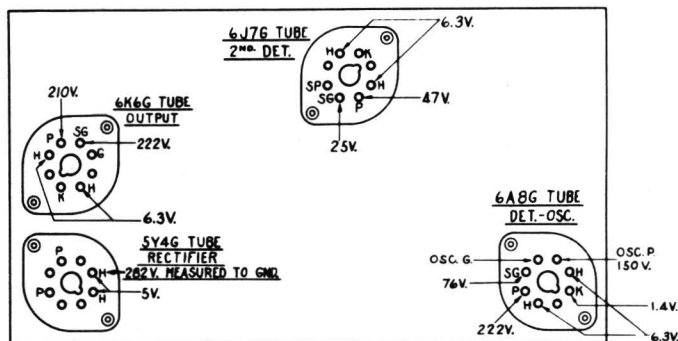

**Fig. 2. Tube Sockets as Viewed from Underside of Chassis. (Measured from Socket Terminal to Ground Volume Control in Maximum Position)**

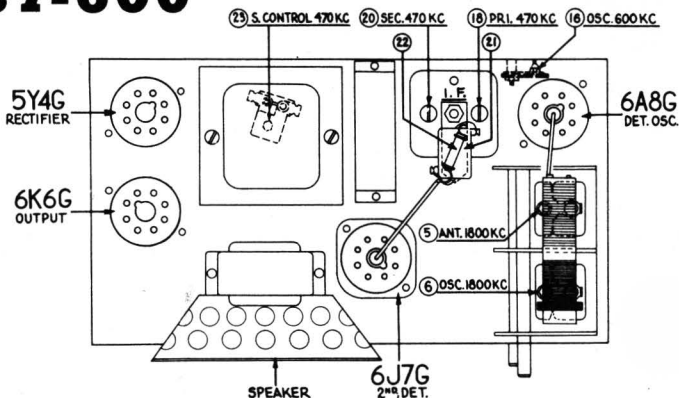

**Fig. 1. Location of Compensators**

**Radio Frequency Circuit**

1. Remove the signal generator output lead from the 6A8G tube, and connect it to the aerial lead of the receiver through a 100 mmfd. condenser.
2. Turn the gang condenser to minimum capacity position, (counter-clockwise) and place a .006" (six-thousandths inch) gauge between the stator and rotor plates. Now turn the gang clockwise until stator and rotor plates touch gauge.
3. Remove gauge from gang condenser. Now set signal generator at 900 K.C., (using second harmonic 1800 K.C.), adjust compensators 6 and 5 for maximum reading on output meter.
4. Turn the signal generator and receiver gang condenser to 600 K.C., and adjust compensator 16. In doing so, the gang condenser must be rolled slightly above and below the 600 K.C. signal until the maximum reading is indicated on the output.
5. Turn the gang condenser to 1800 K.C. and signal generator to 900 K.C., (using second harmonic of signal generator 1800 K.C.), readjust compensator 6 for maximum reading on output meter. Set gang as per paragraph 2, for this adjustment.
6. Turn the gang condenser and signal generator to 1400 K.C., readjust compensator 5 for maximum reading on output meter. After the above adjustments are completed and receiver is placed in the cabinet, the dial pointer is properly placed by turning the signal generator to 1000 K.C. Then tune receiver for maximum signal. The dial pointer is then placed on gang shaft, so that it indicates 1000 K.C. on dial.

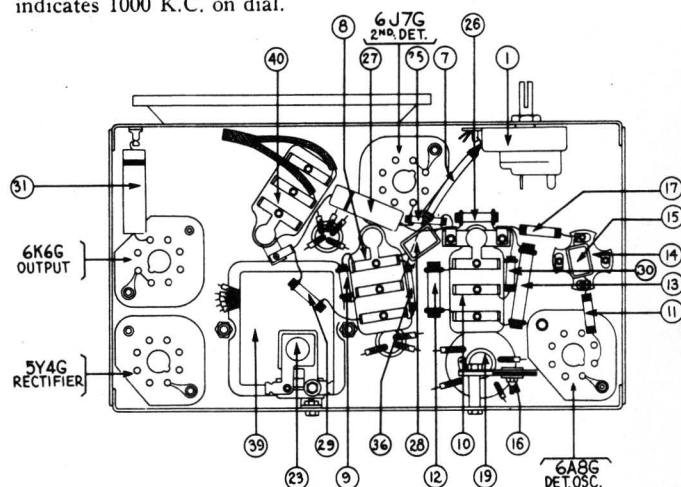

**Fig. 3. Base View**

**Replacement Parts for Model 37-600**

Schematic Number	Part and Description	Part No.	Price List
①	Volume Control	33-5152	\$1.45
②	Condenser (35 Mmf. Mica)	30-1044	.20
③	Ant. Transformer	32-2144	1.40
④	Tuning Condenser	31-1794	3.00
⑤	Compensator (Det. K.C.)	Part of ④	...
⑥	Compensator (Osc. K.C.)	Part of ④	...
⑦	Resistor (300 ohm)	33-3010	.20
⑧	Condenser (.05 mf. Twin Bakelite)	3615-DG	.40
⑨	Resistor (4900 ohm, 1/2 watt)	33-249339	.20
⑩	Condenser (.09 mf. Twin Bakelite)	4989-DG	.40
⑪	Resistor (51,000 ohm, 1/2 watt)	33-351339	.20
⑫	Resistor (25,000 ohm, 1/2 watt)	33-325339	.20
⑬	Resistor (25,000 ohm, 1 watt)	33-325439	.20
⑭	Osc. Transformer	32-2043	1.20
⑮	Condenser (110 mmf. Mica)	30-1031	.20
⑯	Compensator (Osc. Series) (600 K.C.)	04000 S	.35
⑰	Resistor (25,000 ohm, 1/2 watt)	33-325339	.20
⑱	Compensator (I.F. Pri) (460 K.C.)	Part of ⑱	...
⑲	I.F. Transformer	32-2031	1.50

Schematic Number	Part and Description	Part No.	Price List
⑳	Compensator (I.F. Sec.) (460 K.C.)	Part of ⑱	...
㉑	Condenser (50 mmf. Mica)	30-1029	.20
㉒	Resistor (1.5 meg., 1/4 watt)	33-515139	.20
㉓	Sensitivity Compensator	31-6086	.45
㉔	Condenser (.09 mf.)	Part of ⑱	...
㉕	Resistor (10,000 ohm, 1/4 watt)	33-310339	.20
㉖	Resistor (240,000 ohm, 1/2 watt)	33-424339	.20
㉗	Condenser (.01 mf.)	30-4169	.20
㉘	Condenser (.00025 mf.) Mica	30-1032	.25
㉙	Resistor (750,000 ohm, 1/4 watt)	33-475339	.20
㉚	Resistor (10 meg., 1/4 watt)	33-510339	.20
㉛	Condenser (.02 mf.) (Tubular)	30-4113	.20
㉜	Output Transformer	32-7567	1.00
㉝	Voice Coil Cone Assy.	36-3029	.60
㉞	Field Coil Assy.	36-3609	2.50
㉟	Elec. Condenser (4 mf.)	30-2149	1.95
㊱	Resistor (300 ohm)	33-3121	.25
㊲	Condenser (.05 mf.)	Part of ⑱	...
㊳	Elec. Condenser (8.0 mf.)	Part of ⑱	...
㊴	Power Transformer (110 V., 60 Cycle)	32-7552	3.25
㊵	Condenser (.015 mf. Twin)	3793-DG	.40
㊶	Pilot Lamp (6.3 Volt)	34-2064	.09

Schematic Number	Part and Description	Part No.	Price List
	Power Transformer (230 V., 50-60 Cycle)	32-7554	...
	Power Transformer (110 V., 25 Cycle)	32-7553	5.75
	Tube Shield Body	28-2726	.10
	Tube Shield Base	28-3898	.03
	Tube Socket (7-prong)	27-6057	.11
	Tube Socket (8-prong)	27-6058	.11
	Tube Socket (5-prong)	27-6053	.11
	Volume Control Mtg. Nut	W-648-A	.20C
	Chassis Mtg. Screw	W-1656-A	.75C
	Chassis Mtg. Nut	W-124-A	.35C
	Chassis Mtg. Washer	W-151-A	.15C
	Chassis Mtg. Washer	W-291-A	.40C
	Baffle	40-5951	...
	Dial	27-5193	.15
	Knob (Station Selector)	27-4308	.10
	Knob (Volume, On-Off)	27-4309	.10
	Bottom Shield Assy.	29-3795	.40
	Bottom Shield Ins.	27-8122	.05
	Pointer	28-3789	.03
	Pilot Lamp Bracket Assy.	38-7529	.30
	A.C. Cord Assy.	L-2183	.40
	Speaker, B6	36-1205	6.00
	Aerial Lead	38-5144	.30

PRICES SUBJECT TO CHANGE WITHOUT NOTICE

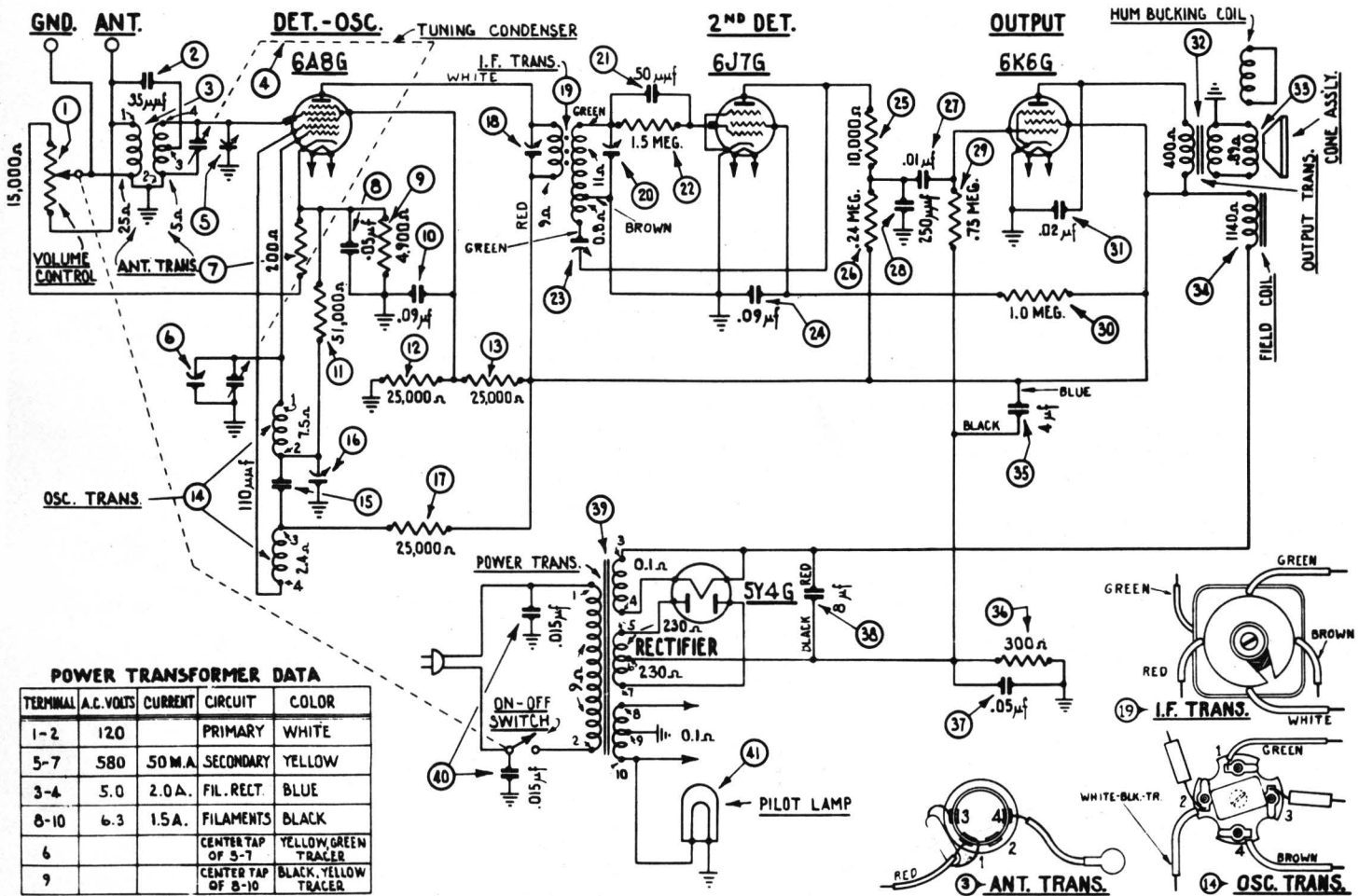

Fig. 4. Schematic Wiring Diagram